

GUARDIAN



Guardian QR700 Canadian Public Safety BDA

TQ-GUARDIAN-QR700



FEATURES

- Provides improved coverage for Public Safety 700 MHz bands for coverage up to 80,000 sq ft
- 80 dB Wideband and 3W EIRP for Public Safety Bands
- Linear Design increases number of simultaneous users to 100+ per band
- Features built-in SureCall Sentry remote monitoring system with Ethernet port
- Integrated 7-pin alarm and UPS port for external battery backup
- Meets Chapter 24 Emergency Communications System of NFPA 72
- NEMA 4 rated amplifier housing. No additional NEMA enclosure(s) needed
- Energy-saving operation allows bands to remain dormant when not in use
- Automatic gain control (AGC)
- Independently adjustable frequency attenuation for uplink and downlink
- Reduce gain in -1 dBm increments

TowerIQ's TQ-GUARDIAN-QR700 Canada Public Safety Band signal booster enhances in-building coverage for crucial communications, delivering consistent signal for First Responders and other public safety officials who rely on two-way radio communication inside large buildings.

TQ-GUARDIAN-QR700 is a Bi-Directional Amplifier that services the growing Public Safety 700 MHz bands for Canada. TQ-GUARDIAN-QR700 meets Chapter 24 of NFPA 72 standards, improving weak First Responder signals for critical and non-critical areas within the building.

In the majority of cases, newly constructed buildings with considerable size, or existing buildings that increase capacity by expanding the building footprint are required to have signal strength of -95 dBm or better in designated critical areas – elevators, stairwells, etc. – in order to receive a certificate of occupancy. TQ-GUARDIAN-QR700 meets the code for NFPA 72 and features a NEMA-4 rated amplifier housing.

Additionally, TQ-GUARDIAN-QR700 comes equipped with dry contact 7-pin alarming compatibility, UPS and Ethernet port enabled remote monitoring. TowerIQ provides an industry leading 3-year warranty.

GUARDIAN



Electrical Specifications

Frequency Range, Uplink	798-806 MHz
Frequency Range, Downlink	768-776 MHz
Channel Bandwidth	
Number of Channels	32
Maximum Output Power, Uplink	27 dBm
Maximum Output Power, Downlink	24 dBm
Maximum System Gain	80 dB
Gain Adjustment Range (1 dB step)	31 dB
Pass Band Ripple, p-p	≤5 dB
Noise Figure	≤8 dB
VSWR	≤ 2.0
Maximum RF Output Power	27 dBm / 24 dBm
Supported Standards	Public Safety 700
Absolute Maximum RF Input Power	
Impedance	

Technical Specifications

Dimensions	21.5 x 17 x 6 inches
Enclosure cooling	Convection
Environmental Class	NEMA4
Operating Humidity	95%
Operating Temperature	-4°F to +131°F
Power Consumption	50W
Power Supply	AC 110 V, 60 Hz
RF Connections	N Female
Weight	49.6 lbs

Example Building Component Layout

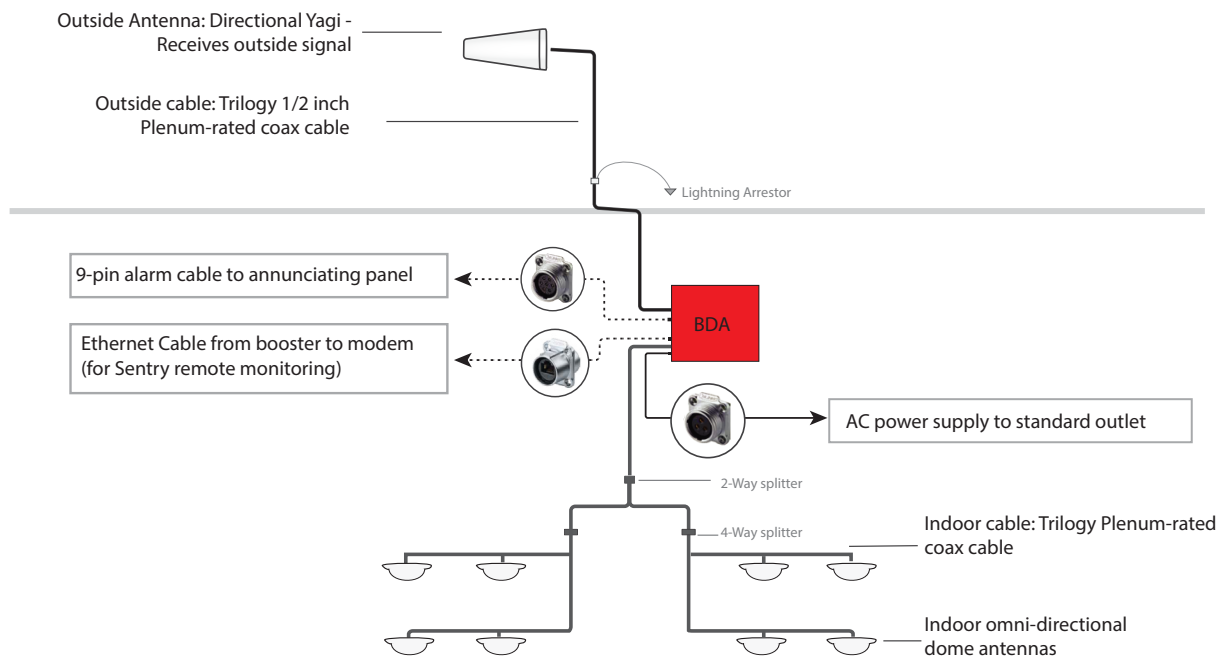



Additional Required Components:

Note: Some component options are listed in table below. Not all accessories are listed.

- One External antenna (directional Yagi)
- Multiple Inside antennas (omnidirectional domes and/or directional panels)
- Cable splitter for inside antennas
- Sufficient TQ-400 ultra-low loss interior/exterior cable, 50 ohm
- Lightning protector
- Grounded surge suppressor for DC power supply

Included Components:

- Guardian QR700 bi-directional amplifier with NEMA-4 rated housing and mounting kit
- Alarm cable and connector
- Ethernet connector
- AC power cable
- DC power cable and connector

Outdoor Antenna Options			
TQ-230W	Directional Wide Band 50 Ω Yagi Antenna (698 - 2700 MHz)	N-Female connectors	10 to 11 dBi
Inside Antenna Options			
TQ-528W	Omni Wide Band Dome 50 Ω Antenna (698 -2700 MHz)	N-Female connectors	3 to 4 dBi
TQ-248W	Directional Wide Band Panel 50 Ω Antenna (698-2700 MHz)	N-Female connectors	7 to 10 dBi
Couplers & Splitters			
TQ-COUP	Wide Band Coupler (698-2700 MHz)	N-Female connectors	
TQ-SPLIT	Wide Band Splitters (698-2700 MHz)	N-Female connectors	
Cable			
TQ-COAX-PL-1000FT	Trilogy 1/2 inch conductor air dielectric cable 1000ft spool		
TQ-COAX-PL-FT	Trilogy 1/2 inch conductor air dielectric cable by foot		

WARNING

THIS IS NOT A CONSUMER DEVICE. IT IS DESIGNED FOR INSTALLATION BY FCC LICENSEES AND QUALIFIED INSTALLERS. USERS MUST HAVE AN FCC LICENSE OR THE EXPRESS CONSENT OF AN FCC LICENSEE TO OPERATE THIS DEVICE.

UNAUTHORIZED USE MAY RESULT IN SIGNIFICANT FORFEITURE PENALTIES, INCLUDING PENALTIES IN EXCESS OF \$100,000 FOR EACH CONTINUING VIOLATION.

Part 90 Signal Boosters. THIS IS A 90.219 CLASS A DEVICE.

Ordering Information

Model	Description	Stock No.
TQ-GUARDIAN-QR700	Canadian Public Safety BDA	3996126